

Report

Financial Impact Assessment for the Waldemar Community, Township of Amaranth, Ontario



Prepared for Sarah Properties Ltd.
by IBI Group

23 April 2015

Document Control Page

CLIENT:	Sarah Properties Ltd.
PROJECT NAME:	Financial Impact Assessment for the Waldemar Community, Township of Amaranth, Ontario
REPORT TITLE:	Financial Impact Assessment for the Waldemar Community, Township of Amaranth, Ontario
IBI REFERENCE:	36214
VERSION:	3
DIGITAL MASTER:	
ORIGINATOR:	Marius Caprariu
REVIEWER:	
AUTHORIZATION:	
CIRCULATION LIST:	
HISTORY:	

Table of Contents

Executive Summary	1
1 Introduction	1
2 Background	2
3 Proposed Sewer Collection System	2
4 Proposed Wastewater Treatment Plant	3
4.1 Flow and Loads to the Wastewater Treatment Plant.....	3
4.2 Effluent Discharge Criteria	4
4.3 Proposed Wastewater Treatment Plant.....	5
5 Project Implementation Phases	5
5.1 Phase 1A	6
5.1.1 Lift Station	6
5.1.2 Wastewater Treatment Plant	6
5.2 Phase 1B	6
5.3 Phase 2.....	7
5.3.1 Lift Station	7
5.3.2 Wastewater Treatment Plant	7
6 Capital Costs Estimates	7
6.1 Phase 1A & B Capital Costs	8
6.2 Phase 2 Capital Costs	8
7 Operation and Maintenance Cost Estimates	9
8 Mitigation Measures for Sustainable Infrastructure	10
APPENDIX A – Waldemar Subdivision, Draft Plan	1
APPENDIX B – Wastewater Treatment Plant, Newterra Proposal	2

Table of Contents (continued)

List of Tables

Table 1 Wastewater Treatment Plant Established Design Parameters	4
Table 2 Wastewater Treatment Plant Effluent Criteria –Surface Discharge	4
Table 3 Phase 1 Capital Costs	8
Table 4 Phase 2 Capital Costs	8
Table 5 Yearly Operation and Maintenance Cost Estimates Phases 1A & B	9
Table 6 Yearly Operation and Maintenance Cost Estimates Phase 2	9

Executive Summary

ES1 – Project Background

The properties are described as part of Lots 2 and 3, Concession 10 and cover an area of 35.02 Ha in the community of Waldemar. The properties are bounded by active farmlands to the west and south, an abandoned railway corridor to the North and the existing Acchione residential subdivision to the East.

The development consists of properties that are currently designated as “Rural” and “Hamlet Residential” in the Township of Amaranth Official Plan. The subject lands are presently vacant and used for agricultural purposes or fallow.

For the planning application, the properties within the site will be developed into a proposed 334-unit subdivision.

The wastewater treatment could accept the sanitary sewage generated from Acchione subdivision and treat it. The sanitation sewer collection system will include stubs for future connection of the Acchione subdivision.

ES2 Sewer Collection System

The municipal sanitary sewer collection system has been divided into two catchments. The highest point in the subdivision is at the intersection of Street 6 and Evans Avenue. Accordingly, the collection system located north of the highest point will drain towards a sanitary lift station located along Street 10. From here the sanitary sewage will be pumped into the gravity system that drains towards the wastewater treatment plant.

ES3 Wastewater Treatment Plant

From the initial consultation with Regulatory Agencies, it is understood that a surface discharge will be acceptable for the proposed facility. Accordingly, the wastewater treatment plant effluent should be in accordance with MOE Guidelines for surface discharge.

ES4 Capital and Operation & Maintenance Cost

The infrastructure works associated with the new wastewater treatment plant will be implemented in three phases, namely: Phase 1A, Phase 1B and Phase 2.

The capital costs (including a 25% contingency) for the three phases is \$2,032,000.00 and the operation and maintenance costs after Phase 2 is \$110,400.00.

This operation and maintenance cost represents \$330/unit/year and is considered as being in line with other municipal costs charged for similar works.

1 Introduction

IBI Group was retained by Sarah Properties Ltd. to prepare a Financial Impact Assessment in support of an Official Plan Amendment, Zoning By-law Amendment and Plan of Subdivision application for a proposed residential development in the Community of Waldemar, Ontario.

The Financial Impact Assessment has been prepared to provide conceptual cost estimates for the capital works and the operation and maintenance costs for the proposed wastewater servicing for residential development.

The report is structured into numerous sections to present the proposed infrastructure works and associated capital and operation and maintenance costs. The main sections of the report are as follows:

- **Section 2 – Background.** This section presents the location of the proposed residential development and depicts existing natural conditions
- **Section 3 – Proposed Sewer Collection System.** This section conceptually presents the proposed sanitary sewer collection system
- **Section 4 – Proposed Wastewater Treatment Plant.** This section conceptually presents the proposed infrastructure works required to treat the sanitary sewage generated within the development to acceptable objectives as established by the Ministry of Environment
- **Section 5 – Project Implementation Phases.** This section presents the implementation phases of the project
- **Section 6 – Capital Cost Estimates.** This section presents the conceptual capital costs estimated for the required infrastructure
- **Section 7 – Operation and Maintenance Cost Estimates.** This section presents the conceptual operation and maintenance costs associated with the proposed operation of the wastewater treatment works
- **Section 8 – Cost Mitigation Measures for Sustainable Infrastructure** This section presents the mitigation measures that will need to be developed to ensure the sustainability of the infrastructure works

2 Background

The properties are described as part of Lots 2 and 3, Concesion10 and cover an area of 35.02 Ha in the community of Waldemar. The properties are bounded by active farmlands to the west and south, an abandoned railway corridor to the North and the existing Acchione residential subdivision to the East.

The development consists of properties that are currently designated as “Rural” and “Hamlet Residential” in the Township of Amaranth Official Plan. The subject lands are presently vacant and used for agricultural purposes or fallow.

For the planning application, the properties within the site will be developed into a proposed 334-unit subdivision.

The wastewater treatment could accept the sanitary sewage generated from Acchione subdivision and treat it. The sanitation sewer collection system will include stubs for future connection of the Acchione subdivision.

3 Proposed Sewer Collection System

The existing Acchione subdivision is comprised of single family residential with individual septic beds. Based on the previous discussions, the Township is receptive to the idea of centralized communal sewage facility; therefore the sanitary services for the proposed development will discharge into a communal sewage wastewater system.

The municipal sanitary sewer collection system has been divided into two catchments. The highest point in the subdivision is at the intersection of Street 6 and Evans Avenue. Accordingly, the collection system located north of the highest point will drain towards a sanitary lift station located along Street 10. From here the sanitary sewage will be pumped into the gravity system that drains towards the wastewater treatment plant.

The second catchment, located south of the highest point in the development, drains by gravity to Block 282, where the wastewater treatment plant will be located.

A second lift station will be located on Block 282 to convey all sanitary sewage generated with the subdivision to the new wastewater treatment plant.

The sanitary sewage flows were calculated using a generation of 450L/cap/day and a population density of 3.0 ppu. Based on these assumptions the average sanitary sewage flows is 451 m³/day or 5.21 L/s and the peak flow is 2,043 m³/day or 23.64 L/s. The detailed calculations of these flows can be found in the Functional Servicing, Preliminary Stormwater Management Report, prepared by C.F Crozier & Associates Inc.

As per the Ministry of Environment (MOE) Guidelines for the Sanitary Sewer Systems, the entire development can be serviced with a minimum diameter sanitary sewer (200mm) installed at minimum slopes (0.4%) or to match steeper road grades as necessary.

Each housing unit will be serviced with a combination of individual and double services as per typical standards. The location of service connections as well as final location and spacing of maintenance holes will be determined during the detailed design phase of the project.

As mentioned above a sanitary lift station will be located in Block 282 of the proposed development. As the project will be implemented into three phases, the lift station will be constructed to accommodate the sewage flows generated in each phase of the project. A more detailed discussion regarding the proposed infrastructure works required at each Project Implementation Phase is presented in Section 5 of this report.

4 Proposed Wastewater Treatment Plant

Design parameters have been established using a variety of sources, including North American water and wastewater design guideline manuals. IBI Group conducted a thorough review and evaluation of these sources and established the following sewage treatment plant design parameters:

- Equivalent population projections for the total site development.
- Average dry weather flow.
- Average annual flow.
- Design (peak hour) flow.
- Wastewater loading conditions.

4.1 Flow and Loads to the Wastewater Treatment Plant

The following assumptions were made in developing the design criteria for the wastewater treatment plant:

No. Units	334
Population/Unit	3.0

Flow per person 450 L/day
 $Development\ Flow = 334 \times 3.0 \times 450 = 450,900\ L/day = 451\ m^3/day\ (ADWF)$

Peak Factor 4.53
 $Peak\ Flow = 451\ m^3/day \times 4.53 = 2,042,577\ L/day$

Table 1 summarizes design parameter values:

Table 1 Wastewater Treatment Plant Established Design Parameters

PARAMETER	FULL SITE DEVELOPMENT
Equivalent Population	1,002
Average Dry Weather Flow	451 m ³ /d
Design (Peak Hour) Flow	2,043 m ³ /d
BOD Load	121 kg/d
BOD Concentration	270 mg/L
TSS Load	121 kg/d
TSS Concentration	270 mg/L
TKN Load	15 kg/d
TKN Concentration	35 mg/L
TP Load	2 kg/d
TP Concentration	5 mg/L

4.2 Effluent Discharge Criteria

From the initial consultation with Regulatory Agencies, it is understood that a surface discharge will be acceptable for the proposed facility. Accordingly, the wastewater treatment plant effluent should be in accordance with MOE Guidelines for surface discharge.

Table 2 Wastewater Treatment Plant Effluent Criteria –Surface Discharge

PARAMETER	ESTABLISHED STANDARDS
pH	6 – 8.5
5-Day Biological Oxygen Demand	< 10 mg/L
COD	< 50 mg/L
Total Suspended Solids	< 10 mg/L
NH ₄ -N	< 0.6 mg/L
TP	< 0.13 mg/L

4.3 Proposed Wastewater Treatment Plant

The proposed wastewater treatment plant will be sized for a surface discharge. Newterra was contacted to provide preliminary schematics of a wastewater treatment plant that will include the following:

- One large equalization tank with a retention capacity of 85 m³
- Two wastewater treatment process trains, each sized to treat an average flow of 150 m³/day. Each process train includes a Membrane Bioreactor as biological treatment
- One 100 m³ sludge disposal tank

For ease of reference the scope of works for the wastewater treatment plant and the preliminary process flow diagram is presented in Appendix A of this report.

5 Project Implementation Phases

The implementation of the project will be split into 3 distinct phases. Each phase will provide a design solution for approximately half of the total houses at the Waldemar Community. The design criteria for the three phases are presented below:

Phase 1A

No. Units	111
Population/Unit	3
Flow per person	450 L/day
	<i>Development Flow = 150 m³/day (ADWF)</i>
Peak Factor	4.53
	<i>Peak Flow = 150 m³/day x 4.53 = 680,000 L/day</i>

Phase 1B

After the implementation of Phase 1, the actual flow data from the development will be taken and the wastewater treatment plant will be rerated for 167 units. Based on the existing influent flows from other developments in the area, we estimate that the wastewater treatment plant will be rerated to accommodate half of the units in the proposed development. Accordingly, in Phase 2 a similar plant will be required to provide treatment capacity for the full development.

Phase 2

No. Units	167
Population/Unit	3
Flow per person	450 L/day
	<i>Development Flow = 225 m³/day (ADWF)</i>
Peak Factor	4.53
	<i>Peak Flow = 132 m³/day x 4.53 = 1,020,000 L/day</i>

The infrastructure works required for each Phase are presented below.

5.1 Phase 1A

In this Phase majority of the infrastructure for the development will be built to reduce the overall capital costs of the project.

5.1.1 Lift Station

The proposed lift station which will be located in Block 286 will be constructed in the third phase. The wet well will be sized to accommodate all the pumps required for the total development. Two (2) submersible pumps (one duty and one standby) will be installed in the wet well. Each pump will be sized to convey the peak flow of 1,020 m³/day to the equalization tank.

A smaller sanitary sewer lift station will be installed in Phase 3, Block 286 to pump all the sewage generated within the northern catchment in to the southern catchment. The sanitary sewer lift station will be equipped with two (2) submersible pumps (one duty and one stand-by), each rated for 380 m³/day.

5.1.2 Wastewater Treatment Plant

The following infrastructure will be implemented during the first phase of the project:

- One equalization tank with a retention capacity of 85 m³
- One wastewater treatment process trains, each sized to treat an average flow of 150 m³/day. The process train includes the following components:
 - Aeration diffuser grid for the equalization tank
 - Two (2) Submersible feed pumps (one duty and one stand-by) from equalization tank to anoxic tank
 - Two (2) positive displacement blowers for the equalization tank
 - Two (2) inlet fine screen with a 2mm opening
 - Anoxic tank
 - Aerobic tank
 - Two (2) positive displacement blowers for the aerobic tank complete with an air diffuser grid
 - One (1) membrane tank complete with flat sheet membranes, positive displacement blower, permeate extraction pumps
 - Clean in Place (CIP) module
 - Chemical dosing system to dose aluminium sulphate
 - One positive displacement blower for the sludge holding tank
 - Complete instrumentation and control system
- One 62.5 m³ disposal tank
- One administration building
- One stand-by generator and the automatic transfer switch

5.2 Phase 1B

In this phase there are no additional infrastructure works required, as only the capacity re-rating of the wastewater treatment plant will be done.

5.3 Phase 2

During the second phase of the project, the wastewater treatment and conveyance system will be upgraded to treat the additional flow that is being generated from 167 units.

5.3.1 Lift Station

One (1) submersible pump (duty) will be added into the existing wet well. The pump will be sized to convey the peak flow of 1,020 m³/day to the equalization tank. In total three (3) submersible pumps will be installed in the wet well to convey the peak flow from entire residential development to the septic tanks.

Both low pressure sewer lines will be operated.

5.3.2 Wastewater Treatment Plant

In the third Phase of the project the wastewater treatment plant will be upgraded with the following works:

- One wastewater treatment process trains, each sized to treat an average flow of 150 m³/day with the following components:
 - One (1) Submersible feed pump (one duty) from equalization tank to the process train 2 anoxic tank
 - Two (2) inlet fine screen with a 2mm opening
 - Anoxic tank
 - Aerobic tank
 - One (1) positive displacement blower for the aerobic tank complete with an air diffuser grid
 - One (1) membrane tank complete with flat sheet membranes, positive displacement blower, permeate extraction pumps
 - Clean in Place (CIP) module
 - Chemical dosing system to dose aluminium sulphate
 - One positive displacement blower for the sludge holding tank
 - Complete instrumentation and control system

6 Capital Costs Estimates

We have developed the capital cost estimates for each phase of the project. The following assumptions were made:

- Concrete. The unit processes were laid out and concrete volumes were calculated. A unit \$1,000 per cubic meter, inclusive of rebar, formwork and installation were used.
- Excavation. For each alternative, the unit processes were laid out and excavation volumes were calculated. A unit cost of \$10 per cubic meter excavated was used.
- Mechanical Equipment. For each alternative, actual quotes were obtained from equipment vendors.

- Mechanical Equipment Installation. A factor has been used to approximate mechanical equipment installation costs. The factor used was 15% of the capital cost for each piece of equipment.
- Electrical. A factor has been used to approximate the capital and installation cost for electrical systems. The factor used was 10% of the subtotal cost for each alternative.
- Instrument & Controls. A cost of \$15,000 was used for each phase for the pumping station. The cost of the instrumentation and control for the wastewater treatment plant is included in the cost of each process train.
- Piping/Valving. The approximate capital and installation costs for piping and valves were assumed equal for each alternative. A unit cost was not included in the alternative evaluation.

6.1 Phase 1A & B Capital Costs

The capital costs associated with Phase 1 of the project are presented in **Table 3** below:

Table 3 Phase 1 Capital Costs

NO.	DESCRIPTION	UNIT	CAPITAL COSTS
1	Excavation	Lump sum	\$20,000
2	Concrete (pad for wastewater treatment plant, equalization and sludge disposal tank)	Lump sum	\$202,000
3	Wet Well	Lump sum	\$30,000
4	Submersible Pumps	Lump sum	\$25,000
5	Wastewater Treatment	Lump sum	\$579,000
6	Stand-by generator	Lump sum	\$50,000
7	Mechanical Equipment Installation	Lump sum	\$87,000
8	Electrical Equipment Installation	Lump sum	\$58,000
9	Low pressure sewer lines	Lump sum	\$60,000
10	Instrumentation, I&C, Control Panel	Lump sum	\$15,000
12	TOTAL COST		\$1,126,000
13	Contingency at 25%		\$281,000
12	TOTAL CAPITAL COST Phase 1		\$1,407,000

6.2 Phase 2 Capital Costs

The capital costs associated with Phase 2 of the project are presented in **Table 4** below:

Table 4 Phase 2 Capital Costs

NO.	DESCRIPTION	UNIT	CAPITAL COSTS
1	Submersible Pumps	Lump sum	\$15,000
2	Wastewater Treatment	Lump sum	\$325,000
3	Mechanical Equipment Installation	Lump sum	\$87,000
4	Electrical Equipment Installation	Lump sum	\$58,000
5	Instrumentation, I&C, Control Panel	Lump sum	\$15,000
6	TOTAL COST		\$500,000
7	Contingency at 25%		\$125,000
8	TOTAL CAPITAL COST Phase 2		\$625,000

7 Operation and Maintenance Cost Estimates

The annual O&M cost includes the following:

- Equipment replacement was determined based on Newterra's proposal
- Equipment labour cost estimated at 8 hours/ week (at \$125/hour for operator including overhead costs)
- Required maintenance was determined based on Newterra's proposal
- Chemical costs were calculated based on the yearly consumption and a cost of \$0.7/L
- Power consumption cost (\$0.10/kWh)

Operating costs were obtained from equipment supplier and are attached in Appendix B of this Report. Additionally, 50 kW/day was added for the operation of the lift station pumps and administration building.

The yearly operating and maintenance costs are identical for each Phase of the project and are presented in **Table 5** below:

Table 5 Yearly Operation and Maintenance Cost Estimates Phases 1A & B

NO.	DESCRIPTION	UNIT	COST
1	Power	Lump sum	\$20,800
2	Maintenance	Lump sum	\$3,000
3	Chemicals	Lump sum	\$7,800
4	Labour	Lump sum	\$25,000
5	Sampling and testing	Lump sum	\$15,000
4	Equipment Replacement	Lump sum	\$13,800
5	ANNUAL O&M COST Per Phase	Lump sum	\$85,400

Additionally, in Phase 2, when the ultimate plant capacity will be implemented the Operation and maintenance costs are presented in Table 7 below:

Table 6 Yearly Operation and Maintenance Cost Estimates Phase 2

NO.	DESCRIPTION	UNIT	COST
1	Power	Lump sum	\$33,800
2	Maintenance	Lump sum	\$5,000
3	Chemicals	Lump sum	\$15,600
4	Labour	Lump sum	\$25,000
5	Sampling and testing	Lump sum	\$15,000
4	Equipment Replacement	Lump sum	\$16,000
5	ANNUAL O&M COST Per Phase	Lump sum	\$110,400

8 Mitigation Measures for Sustainable Infrastructure

In order to mitigate the costs impact associated with the proposed residential development, the following actions need to be taken:

- All capital costs will be transferred to the residential unit through the cost of the unit
- After the implementation of Phases 1A, 1B, and 2 the operation and maintenance costs will be \$330/unit/year. This annual operation and maintenance cost is in line with the costs charged by other municipalities for operating similar facilities.

We recommend that at the completion of the final design of the infrastructure for the proposed residential development this report should be amended to reflect the detailed information.

APPENDIX A – Waldemar Subdivision, Draft Plan



Draft Plan

1 : 2000

Site Data

LOT AREA -	350,207.94 S.M. / 86.54 Ac. / 35.021 Ha.
PARK AREA INCL. BLOCK 282) -	9,879.38 S.M. / 2.44 Ac. / 0.9879 Ha.
RESIDENTIAL LOT AREA -	259,492.82 S.M. / 64.12 Ac. / 25.9 Ha.
ROAD ALLOWANCE AREA -	80,835.74 S.M. / 19.97 Ac. / 8.0836 Ha.
NO. OF LOTS (MIN. 18.3mX36.6m) -	334

* PLANS AND RELATED DOCUMENTS ARE "INSTRUMENTS OF SERVICE". THE INFORMATION CONTAINED HEREIN REMAINS THE PROPERTY OF THE COORDINATOR AND PRINCIPAL PROFESSIONAL(S) AND MUST NOT BE REPRODUCED TO BENEFIT ANY OTHER PROJECT.
 * THE OWNER WARRANTS THAT SITE PLANS AND CONCEPT PLANS WILL BE VERIFIED BY A SURVEYOR TO INCLUDE DIMENSIONS, BEARINGS, SET BACKS, AREA CALCULATIONS, GRADES, F.O.W., EASEMENTS, EDCATIONS, AND ENCROACHMENTS.
 * BUILDING FOUNDATION LAYOUT MUST BE VERIFIED BY A SURVEYOR.
 * PLEASE ASK QUESTIONS IF YOU NEED CLARIFICATION OF INFORMATION FROM "INSTRUMENTS OF SERVICE".
 * IT IS THE RESPONSIBILITY OF THE OWNER, VENDOR, TENANT, CONTRACTOR AND TRADES TO BE FAMILIAR WITH THE PROJECT AS A WHOLE. ALL DISCREPANCIES AND DIMENSIONAL ERRORS ON THE PLANS AND RELATED DOCUMENTS MUST BE REPORTED TO THIS OFFICE FOR CONSIDERATION AND CORRECTIVE RE-DESIGN AND RE-ISSUANCE PRIOR TO THE WORK.

SARAH PROPERTIES LTD.
 2 Prince Edward Road
 Woodstock, Ontario N4V 1G7
 ATTENTION: Mr. Walter Broos (519) 539-7116

date	item	by

Concept Plan

PROJECT:
PROPOSED RESIDENTIAL DEVELOPMENT
 1 EVANS AVE. and 9 MILL ST.
 WALDEMAR ONTARIO

SHEET TITLE:
DRAFT PLAN

DATE: MAR. 25, 2015 DRAWN: M.S.

DP: 1

SHEET No.
 SCALE: 1:2000 COMP. REF. /WALDEMAR/SITE36

APPENDIX B – Wastewater Treatment Plant, Newterra Proposal



newterra™

smart technology. sustainable solutions.™

BUDGET PROPOSAL 1502057R3

Phase One Flow: 150 cubic meters per day

Build Out Flow: 300 cubic meters per day

Waldemar Wastewater Treatment Plant

**newterra MicroClear™ MEMBRANE BIOREACTOR
WASTEWATER TREATMENT SYSTEM**

Submitted To:

Sarah Properties

London, ON
519.539.7116

Attn:

Walter Broos
wbroos@rogers.com

Submitted By:

newterra
3310 South Service Rd., Suite 307
Burlington ON
L7N 3M6

Joe Witlox
Business Development Manager
Cell: 905-299-4682
Office: 800-420-4056 x 1255
jwitlox@newterra.com

Local Representative:

Filtration Resources
108 St. John Street
Cannington, ON
L0E 1E0

Michael Jones
Cell: (705) 330-1892
Office: (705) 432-2116
michael@filtrationresources.com

4/14/2015

At newterra we understand that our performance will have a direct impact on your success of your project. We are extremely committed to ensuring that you are successful. This means that if we do not live up to your expectations, we will do whatever it may take to resolve an issue immediately.

Table of contents

Price Breakdown:	3
newterra MBR System Process Narrative	4
Design Parameters:	5
1. Overview	6
2. Headworks	6
2.1 Equalization Tank	6
2.2 Fine Screens	6
3. Biological Treatment	6
3.1 Anoxic Tank	6
3.2 Aeration Tank	7
3.3 Membrane Tank	7
newterra Scope of Supply	8
Phase 1	9
Phase 2 (Future)	17
Technical Information	23
Appendix 1: Telemetry Control and Remote Access	26
Appendix 2: Process and Flow Diagram	28
Appendix 3: Preliminary Tank Layout	30
Appendix 4: Annual O&M Cost Estimation	32



newterra[™]
smart technology. sustainable solutions![™]

PRICE BREAKDOWN:

Description	PRICE
Estimated Equipment Freight to Site: <ul style="list-style-type: none"> • Includes freight of system to site • Subject to fuel surcharges • Customer is responsible for offloading at site • Customer is responsible for final placement of equipment at the site 	Included
Onsite Startup: <ul style="list-style-type: none"> • Includes five (5) 8-hour days of onsite startup/commissioning and customer training by one factory trained representative. 	Included
Sales Tax on Equipment:	<u>Not Included</u>
Total System Cost (Phase 1)	\$579,000.00
Total System Cost (Phase 2)	\$325,000.00

CURRENCY:

- All prices are quoted in CAN dollars.
- Price valid thirty (30) days from proposal date.

DELIVERY:

Typical newterra shipment occurs 16 to 20 weeks upon written drawing approval.



newterra MBR System Process Narrative



newterra[™]

smart technology. sustainable solutions.[™]

DESIGN PARAMETERS:

Parameters	Phase 1 Design Value	Build out Design Value	Unit
Average Daily Flow (ADF)	150	300	m ³ /d
Maximum Daily Flow (MDF) (assumed)	225	450	m ³ /d
Selected Design Flow, Q _D	6.3	12.6	m ³ /h
Selected Peak Flow, Q _P	9.4	18.8	m ³ /h
Site power	Three-phase, 208V, 60Hz		
System Area Classification	According to NFPA 820		
Ambient temperatures	max: 37 °C, min: -40 °C		
Elevation	<411 m		

INFLUENT WASTEWATER CHARACTERISTICS:

Influent Wastewater Characteristics	Design Value	Unit
Biochemical Oxygen Demand, BOD	222	mg/L
Total Suspended Solids, TSS	244	mg/L
Volatile Suspended Solids, VSS, assumed	196	mg/L
Total Kjeldahl Nitrogen, TKN, assumed	32	mg/L
Ammonia nitrogen, NH ₄ -N, assumed	22	mg/L
Total Phosphorus, TP, assumed	8	mg/L
Fat, Oil and Grease, FOG, assumed	30	mg/L
Minimum water temperature	15	°C
Maximum water temperature, assumed	25	°C
Alkalinity, assumed	300	mg/L

EFFLUENT QUALITY:

Effluent Water Specification	Effluent Limit	Expected	Unit
BOD	<8	<5	mg/L
TSS	<8	<1	mg/L
NH ₄ -N	<0.6	<0.6	mg/L
TP	<0.13	<0.13	mg/L
pH	6.5 - 8.5		-

MBR System Process Narrative

1. Overview

The MBR process differs from traditional municipal treatment systems in that membranes are used to separate solids from treated water. The membranes are submerged in membrane tanks downstream of the traditional processes (anoxic, aeration, etc.). Here the membrane modules separate the solids in the mixed liquor from the water, producing treated effluent called permeate. Since MBRs are capable of operating at elevated MLSS concentrations (8,000 mg/L to 12,000 mg/L in MBRs vs 3,000 mg/L to 4,000 mg/L in conventional systems) they allow for a more compact design, and produce higher quality effluent than conventional systems.

This section outlines the processes used in the newterra Microclear™ MBR system to produce superior quality effluent in accordance with the effluent objectives for BOD/TSS/NH₄-N and TP of 8/8/0.6 and 0.13 mg/L. The primary components used to achieve these effluent objectives consist of fine screens, equalization tank, pre-anoxic tank, aeration tank and membrane tanks.

As shown in the Process Flow Diagram, equalized influent is pumped into the process tanks for biological treatment followed by solid-liquid separation in the membrane tanks using submerged membrane modules. The filtered effluent is then discharged to the distribution system.

1.1 Plant Capacity

The proposed MBR system will take a phased approach to meet the full build out flow of 300 m³/d. Each phase system will have a capacity of 150 m³/d. In this phase 1 proposal, the screen system and sludge management system have been sized and included for the full build out flow.

2. Headworks

2.1 Equalization Tank

One equalization tank is used to buffer the influent flow such that the water level in the aeration tank can be maintained at a desirable level. As well, equalized loadings are distributed throughout the day to optimize the biological performance and to minimize peak hydraulic loads on the membranes. Coarse-bubble air diffusers are used to maintain complete mixed conditions and to prevent odor in the equalization tank.

2.2 Fine Screens

The fine screens remove any debris that might damage the membranes. The screenings are collected in a storage bin, and the effluent from the screen is collected in the screen discharge tank and flows to the downstream process tanks by pumps.

3. Biological Treatment

3.1 Anoxic Tank

The anoxic tank is used for denitrification. Denitrification is the conversion of nitrate to nitrogen gas, and requires an environment containing sufficient nitrates and organics, and minimal oxygen. This process is driven by the influent organics and recycled nitrate from the aeration tank. Since a portion of the organics are removed in the anoxic tank, this reduces the oxygen requirements in the aeration tank ultimately resulting in energy savings. Additionally, the denitrification process increases the alkalinity, thus reducing the requirement for external dosing of alkali chemicals.

Air mixing is provided periodically through coarse bubble diffusers. This maintains complete mixed conditions, with minimal oxygen transfer. Mixed liquor from the pre-anoxic tank flows to the aeration tank by gravity.

3.2 Aeration Tank

In the aeration tank, blowers supply air to the fine-bubble diffusers to provide oxygen for biological oxidation/nitrification and to meet the mixing requirement. The nitrification process consumes alkalinity, which is supplemented by the denitrification process in the pre-anoxic tank.

The oxygen in the aeration tanks is controlled using an operator entered dissolved oxygen (DO) set point (default at 2 mg/L). The speed of the blowers is controlled using a variable frequency drive and real time DO concentration in the aeration tank to maintain the DO set point. This ensures there is sufficient oxygen available for optimal treatment performance, while minimizing energy requirements by preventing over aeration. pH and temperature probes monitor pH and temperature of the mixed liquor in the aerobic basin as well.

Chemical metering pumps are provided to reduce the total phosphorus in the treated effluent. The chemical metering pumps draw alum from the existing chemical container and doses into the aeration tanks. This causes soluble phosphorus to precipitate such that it can be removed through membrane filtration.

3.3 Membrane Tank

In the membrane tanks solid-liquid separation is achieved with ultrafiltration membranes. The treated water, also called permeate or filtrate, is pulled through the flat sheet ultrafiltration membranes by the permeate pumps under a slight vacuum of 0.07 to 0.20 bar (1 to 2.9 psi). Vacuum pumps operate on a cyclic basis between permeation and relaxation (no permeation), with continuous air scouring. A typical permeate cycle consists of 9 minutes permeation and 1 min relaxation.

Scour air is introduced to the bottom of the membrane unit through medium bubble diffusers, dispersing air evenly across all membrane plates. The air bubbles rise tangential to the membrane surface, providing a continuous shear force to remove cake build up on the membranes. As such, membranes are kept clean to the maximum extent during operation. The medium-bubble air diffusers also provide oxygen credit, which complements the biological oxidation and nitrification process taking place in the aeration tank, thereby reducing the overall process air requirements. This results in considerable energy savings and aeration operating costs. Solids, including organics, bacteria and most viruses are rejected at the membrane surface and retained in the membrane tank. The mixed liquor is continuously recycled to the pre-anoxic tank, by pump, to maintain even biomass distribution amongst the process tanks and to minimize the solids build-up in the membrane tanks for membrane fouling control.

The Membrane Clean-in-Place (CIP) system supplies dilute cleaning chemicals to remove any accumulation of organics on the membrane surface. A backwash system allows the membrane cassettes to be filled with cleaning chemicals through the permeate lines. This greatly reduces the quantity of chemicals required for cleaning.



newterra[™]

smart technology. sustainable solutions.[™]

newterra Scope of Supply



PHASE 1

EQUALIZATION TANK COMPONENTS			
One (1) EQ tank by others with the following items supplied loose for the tank:			
Description:	Capacity	Motor HP	Quantity
In ground tank – By others	85 m ³	N/A	N/A
Instrumentation: <ul style="list-style-type: none"> • Level transmitter • Level alarm switch 	N/A	N/A	1
Air diffusers grid: <ul style="list-style-type: none"> • Coarse bubble air diffusers • 304 SS Air manifold • 304 SS Drop leg 	N/A	N/A	1
Submersible Feed Pump to Anoxic tank <ul style="list-style-type: none"> • One (1) duty, one (1) standby • Model : Zoeller BA292 or equal • Outlet size: 2" • 208V/3PH/60Hz motor • Rail system and brackets 	18.8 m ³ /h	0.5 (0.37 kW)	2

EQUALIZATION BLOWER			
(Inside newterra enclosure)			
Description:	Capacity	Motor HP	Quantity
Regenerative blower package: <ul style="list-style-type: none"> • One (1) duty, One (1) stand-by • Check valves • Isolation valves • Low pressure alarm switch • Pressure gauge • Temperature gauge • Pressure relief valve • Inlet Filter / Silencer 	72.6 Nm ³ /h	3.4 (2.5 kW)	2

INLET FINE SCREEN COMPONENTS (Inside newterra enclosure)			
Description:	Capacity	Motor HP	Quantity
Rotary Brush Screen <ul style="list-style-type: none"> • One (1) duty, one (1) standby for ADF • Model: Or-TEC ODS-4 • Punch perforated plate - 2mm openings • Level sensor • Xproof motor 	Max. 130 gpm (8.2 l/s)	0.5 (0.37 kW)	2
Influent flow transmitter <ul style="list-style-type: none"> • Electromagnetic flow transmitter • Grounding rings 	N/A	N/A	1
External Transfer Pumps: <ul style="list-style-type: none"> • One (1) duty, one (1) standby • Model : Price RC 200 • Outlet size 2" • 208V/3PH/60Hz motor • Pressure gauge 	9.4 m ³ /h	0.75 (0.56 kW)	2

ANOXIC TANK COMPONENTS (Inside newterra enclosure)			
Description:	Capacity	Motor HP	Quantity
Instrumentation: <ul style="list-style-type: none"> • High level alarm switch 	N/A	N/A	1
Immersion Heater	N/A	6 KW	1
Air diffusers grid: <ul style="list-style-type: none"> • Coarse bubble air diffusers • PVC Air manifold • PVC Drop leg 	N/A	N/A	1

AEROBIC TANK COMPONENTS
(Inside newterra enclosure)

Description:	Capacity	Motor HP	Quantity
Instrumentation: <ul style="list-style-type: none"> • Level transmitter • High level alarm switch • DO transmitter • pH transmitter • Temperature Switch 	N/A	N/A	1
Immersion Heater	N/A	6 KW	2
Air diffusers grid: <ul style="list-style-type: none"> • Fine bubble air diffusers • PVC Air manifold • PVC Drop leg 	N/A	N/A	1
Membrane Feed Pumps: <ul style="list-style-type: none"> • One (1) duty, one (1) standby • Model: Price RC 200 • 208V/3PH/60Hz motor • Pressure gauges 	31.3 m ³ /h	2 (1.5 kW)	2

AEROBIC BLOWER
(Inside newterra enclosure)

Description:	Capacity	Motor HP	Quantity
Regenerative blower package: <ul style="list-style-type: none"> • One (1) duty, one (1) standby • Check valves • Isolation valve • Low pressure alarm switch • Pressure gauge • Temperature gauge • Pressure relief valve • Inlet Filter / Silencer • VFD controlled 	212.3 Nm ³ /h	8.5 (6.3 kW)	2

MEMBRANE TANK COMPONENTS
(Inside newterra enclosure)

Description:	Capacity	Motor HP	Quantity
316L SS membrane tank with front access door for ease of maintenance.	8.0 m ³	N/A	1
Instrumentation: <ul style="list-style-type: none"> High level alarm switch 	N/A	N/A	2
MB3-3 MicroClear™ flat sheet membrane module with: <ul style="list-style-type: none"> 304SS Construction Full surface distribution Medium bubble scouring Laser sheet welding 	N/A	N/A	1

MEMBRANE BLOWER
(Inside newterra enclosure)

Description:	Capacity	Motor HP	Quantity
Regenerative blower package: <ul style="list-style-type: none"> One (1) duty, one (1) standby Check valves Isolation valve Low pressure alarm switch Pressure gauge Temperature gauge Pressure relief valve Inlet Filter / Silencer 	75 Nm ³ /h	3.4 (2.5 kW)	2

PERMEATE EXTRACTION SYSTEM (Inside newterra enclosure)			
Description:	Capacity	Motor HP	Quantity
Instrumentation: <ul style="list-style-type: none"> • Permeate flow transmitter • Vacuum transmitter • Vacuum gauge • Pressure gauge 	N/A	N/A	1
Permeate extraction pump: <ul style="list-style-type: none"> • One (1) duty, one (1) standby • Model: Gorman-Rupp Self-priming pump 81.5D3 • Suction / Discharge flange size: 1 ½ ” • 230V/3PH/60Hz motor • VFD controlled 	10.4 m ³ /h	0.5 (0.37 kW)	2

CIP MODULE (Inside newterra enclosure)			
Description:	Capacity	Motor HP	Quantity
Clean-In-Place (CIP) tank <ul style="list-style-type: none"> • Polyethylene cleaning solution tank • One (1) Backwash pump 	135 L	N/A	1

CHEMICAL DOSING SYSTEM (Inside newterra enclosure)			
Description:	Capacity	Motor HP	Quantity
Alum dosing system: <ul style="list-style-type: none"> • One (1) duty • One (1) Shelf spare • One (1) Portable eye wash system • Spill tray • Chemical Storage tote or drum by others 	121.9 L/d	N/A	1

SLUDGE HOLDING TANK COMPONENTS (Inside newterra enclosure)			
Description:	Capacity	Motor HP	Quantity
In ground tank – By others	100 m ³	N/A	N/A
Instrumentation: <ul style="list-style-type: none"> High level alarm switch 	N/A	N/A	1
Air diffusers grid: <ul style="list-style-type: none"> Coarse bubble air diffusers 304 SS Air manifold 304 SS Drop leg 	N/A	N/A	1
Decant Pump: <ul style="list-style-type: none"> Model: Price RC 200 Inlet size: 2" Outlet size: 2" 208V/3PH/60Hz motor 	15 m ³ /h	1 (0.75 kW)	1

SLUDGE HOLDING TANK BLOWER (Inside newterra enclosure)			
Description:	Capacity	Motor HP	Quantity
Regenerative blower package: <ul style="list-style-type: none"> One (1) duty Check valves Isolation valve Low pressure alarm switch Pressure gauge Temperature gauge Pressure relief valve Inlet Filter / Silencer 	106.7 Nm ³ /h	6.2 (4.6 kW)	1

CONTROL PANEL

(Inside newterra enclosure)

Description:

Quantity

Control System

Schneider Electric M258 based control panel with the following standard features:

- NEMA 12 PLC control panel with user interface touchscreen
- Fused main disconnect
- Surge and lightning protection for control system
- Main power block
- Branch circuit protection with circuit breakers for powered devices and control system power
- UPS for PLC
- 24 VDC IS power supply
- Duplex 15 Amp GFI receptacle
- Factory tested prior to shipping
- Outside cover of inner swing panel to contain the following:
 - Power on light
 - Red alarm indicator light
 - 10" Programmable user display/touch screen HMIDTO5310
 - Emergency stop button

1

SYSTEM ENCLOSURES

Description:

Quantity

Three (3) 40' Modified Shipping Containers cMET certified, built to NEC standards with all wiring complete and all equipment pre-piped factory tested and mounted in enclosure.

Once-used high cube modified shipping containers with the following standard features:

- Stacked alarm light
- Exterior paint
- Lifting eyes on upper corners
- Steel floor
- Insulated walls, ceiling, and floor
- Welded steel man door with safety window and crash-bar
- Barn-style rear double doors
- Lighting
- Heating
- Ventilation fans
- Passive vent louvers with hoods
- Emergency stop switch
- Low temperature alarm switch
- Duplex 15 Amp GFI receptacle for heat trace inlet and discharge

1

OPERATION AND MAINTENANCE MANUAL

Description:	Quantity
<ul style="list-style-type: none"> • Operating instructions for all treatment system components • Copy of operating manual for each piece of equipment • Summary of system components • Summary of system operation principles • Summary of operation controls and failsafes • Summary of maintenance requirements for each piece of equipment • Two hard copies and one electronic provided 	2

CLIENT'S SCOPE OF SUPPLY AND WORK

Description:
<ul style="list-style-type: none"> • Firm, level base for newterra supplied equipment • Installation of loose shipped equipment supplied by newterra; • Placement and anchoring (if required) of equipment; • Piping hookups to and from the newterra treatment system; • Electrical power supply to our electrical panel, lightning, grounding, etc. ; • Communication wiring between newterra control panel and client control system; • Delivery of raw sewage to the newterra MBR STP; • Permitting; • Grease trap to control entry of oil and greasy material to the newterra MBR; • Piping hookups from the newterra MBR to Distribution system; • Potable water supply to the plant site for plant hydraulic test during startup; • Seed sludge; • Wastewater testing; • Chemicals supply and storage; • Treated effluent and waste sludge disposal; • All civil work • All civil works design and drawings • All interconnecting piping, and wiring for power and controls between loose ship equipment and control panel. • Anything not mentioned in "Scope of Supply" above.

PHASE 2 (FUTURE)

FEED PUMP (Shipped loose for installation by others)			
Description:	Capacity	Motor HP	Quantity
External Transfer Pumps: <ul style="list-style-type: none"> • One (1) duty • Model : Price RC 200 • Outlet size 2" • 208V/3PH/60Hz motor • Pressure gauge 	9.4 m ³ /h	0.75 (0.56 kW)	1

ANOXIC TANK COMPONENTS (Inside newterra enclosure)			
Description:	Capacity	Motor HP	Quantity
Instrumentation: <ul style="list-style-type: none"> • High level alarm switch 	N/A	N/A	1
Immersion Heater	N/A	6 KW	1
Air diffusers grid: <ul style="list-style-type: none"> • Coarse bubble air diffusers • PVC Air manifold • PVC Drop leg 	N/A	N/A	1

AEROBIC TANK COMPONENTS (Inside newterra enclosure)			
Description:	Capacity	Motor HP	Quantity
Instrumentation: <ul style="list-style-type: none"> • Level transmitter • High level alarm switch • DO transmitter • pH transmitter • Temperature Switch 	N/A	N/A	1
Immersion Heater	N/A	6 KW	2
Air diffusers grid: <ul style="list-style-type: none"> • Fine bubble air diffusers • PVC Air manifold • PVC Drop leg 	N/A	N/A	1
Membrane Feed Pumps: <ul style="list-style-type: none"> • One (1) duty • Model: Price RC 200 • 208V/3PH/60Hz motor • Pressure gauges 	31.3 m ³ /h	2 (1.5 kW)	1

AEROBIC BLOWER (Inside newterra enclosure)			
Description:	Capacity	Motor HP	Quantity
Regenerative blower package: <ul style="list-style-type: none"> • One (1) duty • Check valves • Isolation valve • Low pressure alarm switch • Pressure gauge • Temperature gauge • Pressure relief valve • Inlet Filter / Silencer • VFD controlled 	212.3 Nm ³ /h	8.5 (6.3 kW)	1

MEMBRANE TANK COMPONENTS
(Inside newterra enclosure)

Description:	Capacity	Motor HP	Quantity
316L SS membrane tank with front access door for ease of maintenance.	8.0 m ³	N/A	1
Instrumentation: <ul style="list-style-type: none"> High level alarm switch 	N/A	N/A	2
MB3-3 MicroClear™ flat sheet membrane module with: <ul style="list-style-type: none"> 304SS Construction Full surface distribution Medium bubble scouring Laser sheet welding 	N/A	N/A	1

MEMBRANE BLOWER
(Inside newterra enclosure)

Description:	Capacity	Motor HP	Quantity
Regenerative blower package: <ul style="list-style-type: none"> One (1) duty Check valves Isolation valve Low pressure alarm switch Pressure gauge Temperature gauge Pressure relief valve Inlet Filter / Silencer 	75 Nm ³ /h	3.4 (2.5 kW)	1

PERMEATE EXTRACTION SYSTEM
(Inside newterra enclosure)

Description:	Capacity	Motor HP	Quantity
Instrumentation: <ul style="list-style-type: none"> • Permeate flow transmitter • Vacuum transmitter • Vacuum gauge • Pressure gauge 	N/A	N/A	1
Permeate extraction pump: <ul style="list-style-type: none"> • One (1) duty • Model: Gorman-Rupp Self-priming pump 81.5D3 • Suction / Discharge flange size: 1 ½ ” • 230V/3PH/60Hz motor • VFD controlled 	10.4 m ³ /h	0.5 (0.37 kW)	1

CHEMICAL DOSING SYSTEM
(Inside newterra enclosure)

Description:	Capacity	Motor HP	Quantity
Alum dosing system: <ul style="list-style-type: none"> • One (1) duty • One (1) Portable eye wash system • Spill tray • Chemical Storage tote or drum by others 	121.9 L/d	N/A	1

CONTROL PANEL

(Inside newterra enclosure)

Description:

Quantity

Control System

Schneider Electric M258 based control panel with the following standard features:

- NEMA 12 PLC control panel with user interface touchscreen
- Fused main disconnect
- Surge and lightning protection for control system
- Main power block
- Branch circuit protection with circuit breakers for powered devices and control system power
- UPS for PLC
- 24 VDC IS power supply
- Duplex 15 Amp GFI receptacle
- Factory tested prior to shipping
- Outside cover of inner swing panel to contain the following:
 - Power on light
 - Red alarm indicator light
 - 10" Programmable user display/touch screen HMIDTO5310
 - Emergency stop button

1

SYSTEM ENCLOSURES

Description:

Quantity

Two (2) 40' Modified Shipping Containers cMET certified, built to NEC standards with all wiring complete and all equipment pre-piped factory tested and mounted in enclosure.

Once-used high cube modified shipping containers with the following standard features:

- Exterior paint
- Lifting eyes on upper corners
- Steel floor
- Insulated walls, ceiling, and floor
- Welded steel man door with safety window and crash-bar
- Barn-style rear double doors
- Lighting
- Heating
- Ventilation fans
- Passive vent louvers with hoods
- Low temperature alarm switch
- Duplex 15 Amp GFI receptacle for heat trace inlet and discharge

1

CLIENT'S SCOPE OF SUPPLY AND WORK

Description:

- Firm, level base for newterra supplied equipment
- Installation of loose shipped equipment supplied by **newterra**;
- Placement and anchoring (if required) of equipment;
- Piping hookups to and from the **newterra** treatment system;
- Electrical power supply to our electrical panel, lightning, grounding, etc. ;
- Communication wiring between **newterra** control panel and client control system;
- Delivery of raw sewage to the newterra MBR STP;
- Permitting;
- Grease trap to control entry of oil and greasy material to the newterra MBR;
- Piping hookups from the newterra MBR to Distribution system;
- Potable water supply to the plant site for plant hydraulic test during startup;
- Seed sludge;
- Wastewater testing;
- Chemicals supply and storage;
- Treated effluent and waste sludge disposal;
- All civil work
- All civil works design and drawings
- All interconnecting piping, and wiring for power and controls between loose ship equipment and control panel.
- Anything not mentioned in "Scope of Supply" above.



newterra[™]

smart technology. sustainable solutions.[™]

Technical Information



UNIQUE FEATURES OF MICROCLEAR™ MEMBRANES:

newterra MicroClear™ membranes provide the following unique features:

- Low electric power consumption - filtrate is drawn through and out of the filter by a slightly negative pressure (vacuum) of only 0.07 – 0.1 bar (1 to 2.9 psi)
- Membrane sheet-to-backing sheet welding by laser – perfect welding, ensures no ingress of dirty wastewater into the clean permeate



Laser-welded Flat Plate Membrane during Pressure Test

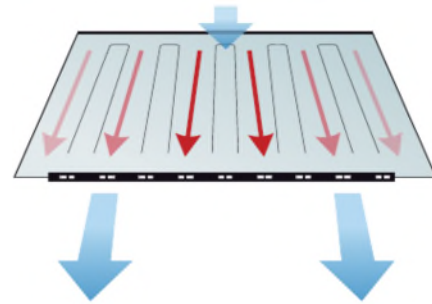

FSD™ (full surface distribution)

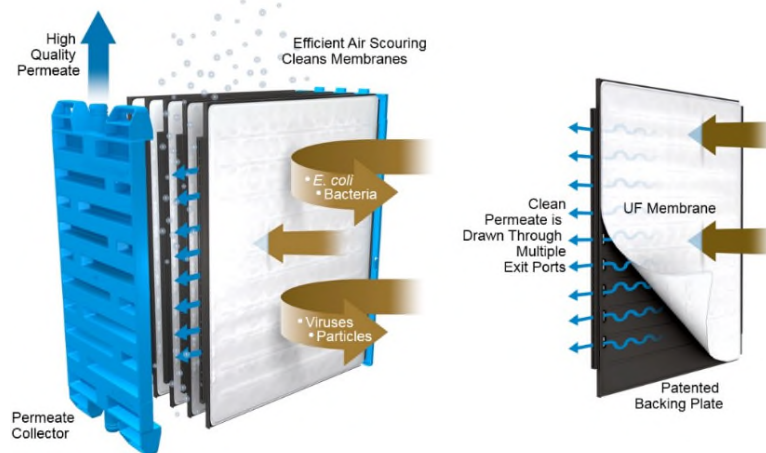

- UF membranes with a molecular weight cut-off of 150k Dalton, equivalent to a pore size of 0.04 μm , leaving out any bacteria (1 – 2 μm), parasites (5 – 50 μm), with a bacteria removal of 99.9999% and virus removal of 99.99%
- Cleaning during operation by cyclic backflushing
- Patented special design of backing sheet surface – thus no need for a gauze between the membrane and backing sheets to prevent adhesion
- FSD™ (full surface distribution) – full membrane surface utilization for permeate collection by multiple outflow points, thus no short-circuiting and even flux distribution
- Easily expandable with modular design

PROHIBITED ITEMS:

- A complete list of prohibited chemicals is included in the membrane maintenance manual.

1502057R3

Page 24

ADVANTAGES OF **newterra** MBR SYSTEM:

The **newterra** MBR system employs membrane biological reactor (MBR) technology with submerged **MicroClear**[™] membranes. The system is designed to be the simplest, most operator-friendly flat plate membrane technology available in the market. The **newterra** MBR system produces ultra-clean water (solids free effluent) which effectively meets any water standards for discharge and reuse.

The **newterra** MBR system is a packaged wastewater treatment plant with modular design features. The system comes complete with containerized screen pre-anoxic tank and membrane tanks. The plant is housed inside modified high-cube shipping containers or prefabricated buildings - completely pre-assembled, pre-piped, pre-wired and pre-tested, ready for a quick site installation and start-up. The advantages that the **newterra** MBR system offers include:

- Absolute physical barrier for solids, bacteria and viruses;
- Short delivery period;
- Factory assembled and tested;
- Minimal construction work on site;
- Easy to relocate;
- Reliable and low maintenance system;
- Superior effluent quality that is suitable for reuse;
- Compact footprint;
- Minimal noise and odourless operation;
- Backflushable flat plate membrane system;
- Low transmembrane pressure system – only 0.1 to 0.2 bar vacuum required;
- Excellent membrane structure life;



Appendix 1: Telemetry Control and Remote Access



newterra[™]
smart technology. sustainable solutions.[™]

OPTIONAL TELEMETRY CONTROL AND REMOTE ACCESS:

One-time hardware cost plus one (1) year telemetry service: Included
Hardware: EWON & Modem

Annual telemetry service contract: \$ 1,825/year

newterra SITE-LINK is a customized software program and hardware configuration which provides a real-time link to a treatment system via cellular modem or customer supplied internet connection using advanced VPN technology. An annual Telemetry Service Agreement with **newterra** is required which includes all costs associated with the service.

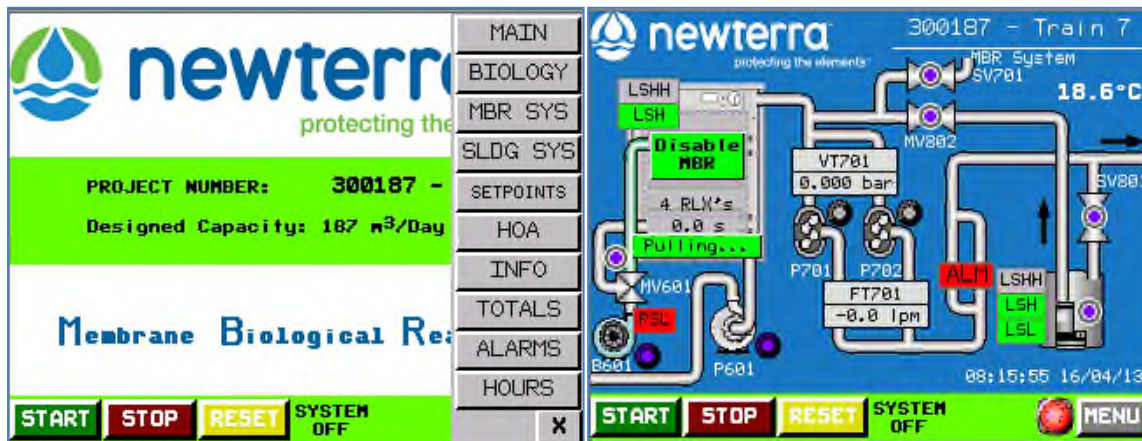

newterra Site-Link comes with the following customizable features:

- Customized P&ID layout with system status
- Start/Stop/Reset of system
- Manual control of all system components
- Data logging downloads in .csv format†
- Daily system status reports (E-Monitor)
- Alarm history including current alarm status
- Hour meters for applicable equipment
- Customization of all system set points†
- Live and historical trending
- Immediate text & email on alarm (E-Alarm)

†certain restrictions apply

The basic system requires that the customer provide a standard computer network cable to the control panel. If the customer's computer network is accessible to the internet, this system can also be monitored from any internet enabled computer. Static IP is not required but is recommended and must be provided by customer.

This system is not available if customer supplied internet connection or cellular service is not available at the site. During internet outages, reports cannot be sent and system status cannot be monitored remotely.

Appendix 2: Process and Flow Diagram



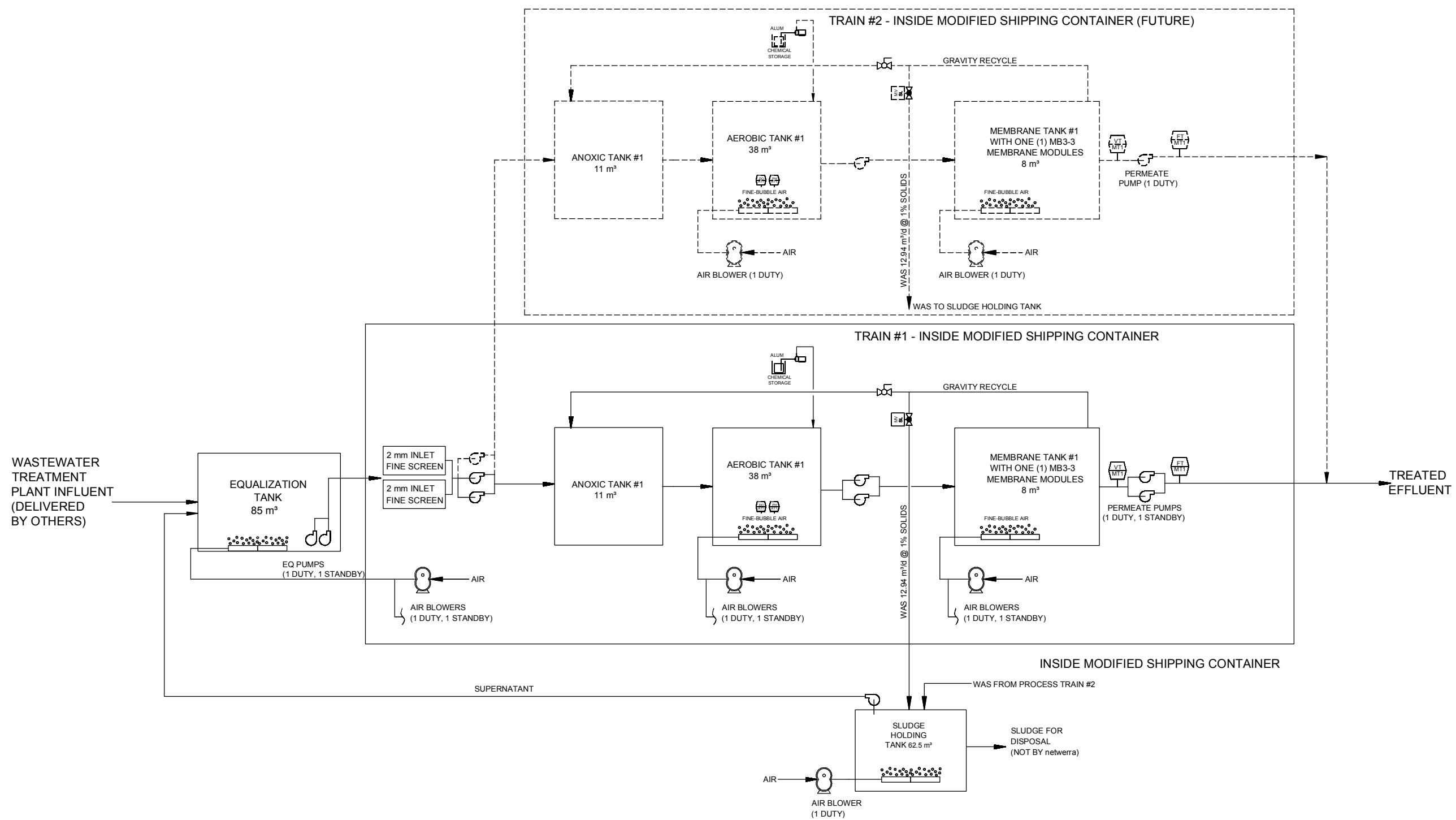

NOTES



PHONE:
(800) 420-4056
www.newterra.com

R2	FOR QUOTE	03/27/15	NK
R1	FOR QUOTE	10/28/14	JVDH
R0	FOR QUOTE	10/09/14	JSN
LEVEL	REVISION	DATE (mm/dd/yy)	BY

PROJECT NUMBER	1502057
TITLE AND LOCATION	PROCESS FLOW DIAGRAM newterra MicroClear™ MBR WWTP Waldemar WWTP, ON

CUSTOMER Sarah Properties			
DRAWN BY	DATE	SHEET	SHEETS
NK	03/27/15	1	1

Appendix 3: Preliminary Tank Layout



newterra[™]
smart technology. sustainable solutions.[™]

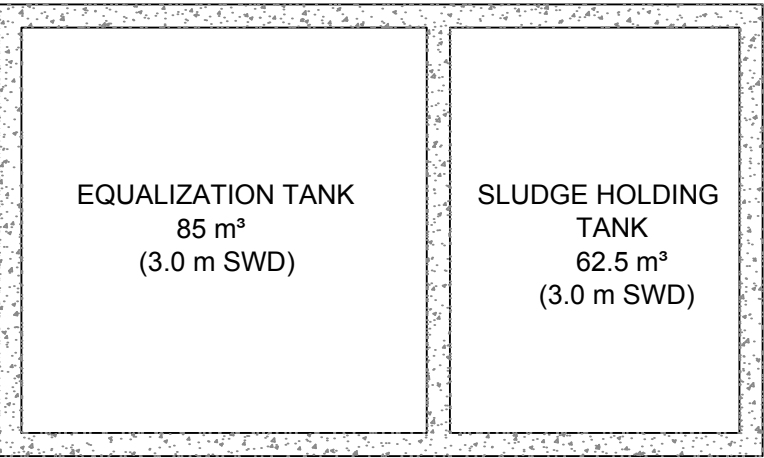

PHASE 1 SYSTEM

PROCESS TRAIN #1

PROCESS TRAIN #2
(FUTURE)

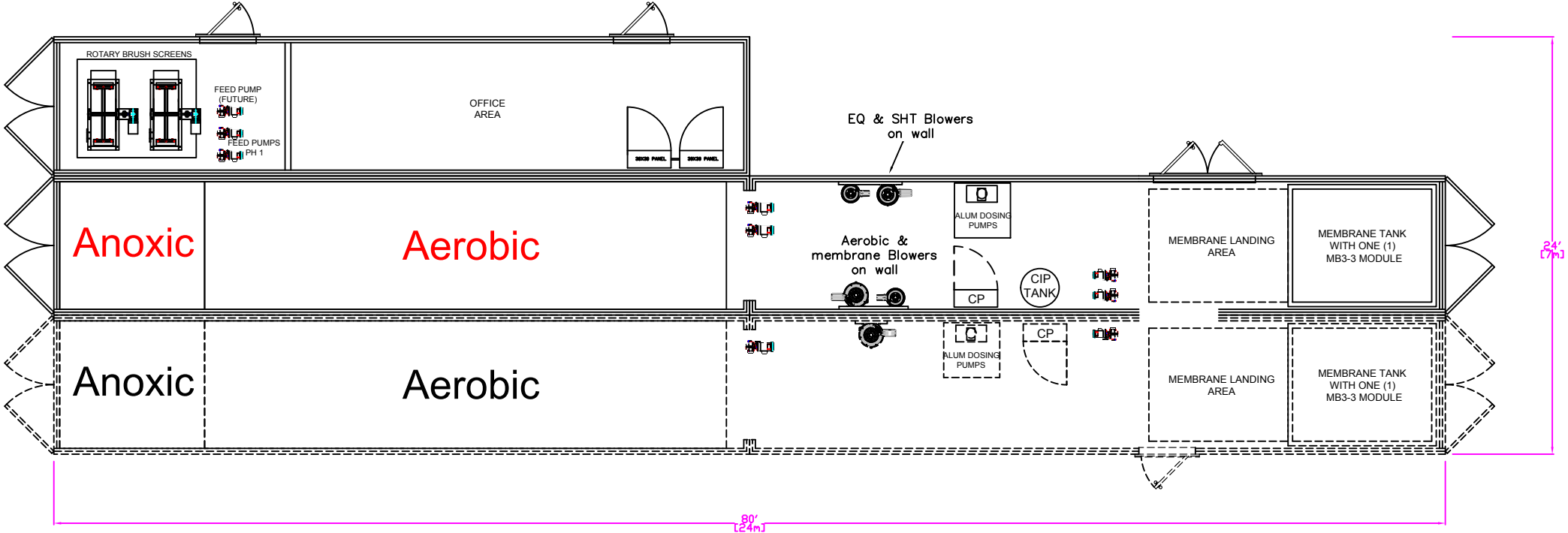

80' [24m]

24' [7m]

NOTES		PHONE:	PROJECT NUMBER		CUSTOMER	
		(800) 420-4056	1502057	SARAH PROPERTIES		
		www.newterra.com	TITLE AND LOCATION		DRAWN BY	
			PROCESS FLOW DIAGRAM	DATE		SHEET
			newterra MicroClear™ MBR WWTP	03/26/15		1
		WALDEMAR DEVELOPMENT, ON	BY	1	1	

THIS INFORMATION IS THE PROPERTY OF newterra AND CANNOT BE REUSED OR REPRODUCED WITHOUT THE WRITTEN CONSENT OF newterra

Appendix 4: Annual O&M Cost Estimation

1. Phase 1 system
2. Phase 2 system



newterra[™]
smart technology. sustainable solutions.[™]

Project No.: 1502057 - Phase 1 train

Project Name: Waldemar, ON, Wastewater Treatment Plant



Chemical Consumption Estimation

Membrane Tanks in Service: 1

Chlorine CIP Cleaning Frequency: 4 per year

Chlorine Recovery Cleaning Frequency: 1 per year

Citric Acid Recovery Cleaning Frequency: 1 per year

Purpose	Chemical	Bulk Chemical Concentration	Required Solution Concentration	Required Bulk Chemical per Procedure	Number of Procedures per Cell per Year	Number of Procedures per Year	Required Bulk Chemical per Year
1. Membrane Cleaning Chemicals							
Chlorine Clean-In-Place	Sodium Hypochlorite	12.0% w/w Liquid	500 ppm	0.6 L 0.7 kg	4	4	2.3 L 2.7 kg
Chlorine Recovery Clean	Sodium Hypochlorite	12.0% w/w Liquid	500 ppm	41.9 L 49.9 kg	1	1	41.9 L 49.9 kg
Citric Acid Recovery Clean	Citric Acid	30.0% w/w Liquid	0.5% w/w Liquid	100.6 L 112.7 kg	1	1	100.6 L 112.7 kg
2. Process Chemicals							
Alum dosing	Alum	N/A	N/A	30.5 L/d 40.73 kg/d	Continuous	Continuous	11,127.6 L 14,866.52 kg

Project No.: 1502057 - Phase 1 train

Project Name: Waldemar, ON, Wastewater Treatment Plant



Estimated Power Consumption

Equipment	Qty. Duty	Qty. Standby	Nameplate hp	Consumed hp at duty point	Total Installed hp	Total Consumed hp at duty point	Motor Efficiency	Total Operating hp	Total Operating kW	Daily Run Time (h/d)	Daily Operating (kWh/d)
Equalization Tank											
Air Blowers	1	1	3.4	3.3	6.80	3.3	80.00%	4.13	3.08	24	73.9
EQ Pumps	1	1	0.5	0.45	1.00	0.45	85.00%	0.53	0.39	4	1.6
Headworks											
Fine Screens	1	1	0.5	0.5	1.00	0.5	75.00%	0.67	0.50	4	2.0
Feed Pumps	1	1	0.75	0.72	1.50	0.72	75.00%	0.96	0.72	16	11.5
Anoxic Tank											
Immersion Heater	1	0	4	4	4.00	4	100.00%	4.00	2.98	8	23.9
Aeration Tank											
Immersion Heater	2	0	6.7	6.7	13.40	13.4	100.00%	13.40	10.00	8	80.0
Air Blowers	1	1	8.5	6.7	17.00	6.7	80.00%	8.38	6.25	24	149.9
Membrane Feed Pumps	1	1	2	1.6	4.00	1.6	85.00%	1.88	1.40	24	33.7
MBR Tank											
Air Scour Blowers	1	1	3.4	2.2	6.80	2.2	80.00%	2.75	2.05	22	45.1
Permeate Pumps	1	1	0.5	0.4	1.00	0.4	75.00%	0.53	0.40	20	8.0
Sludge Holding Tank											
Air Blower	1	0	6.2	4.7	6.20	4.7	80.00%	5.88	4.38	20	87.7
Decant Pump	1	0	1	0.8	1.00	0.8	75.00%	1.07	0.80	4	3.2
Sum					63.70	38.77			32.95		520.30

Project No.: 1502057 - Phase 1 train
 Project Name: Waldemar, ON, Wastewater Treatment Plant



Estimated Capital Equipment Replacement/Repair Cost

Maintenance Costs	Frequency (years)	Qty in system	Cost (\$)	Annual Cost (\$)
DO sensor	1 years	1	\$850	\$ 850
pH sensor	1 years	1	\$850	\$ 850
Screen Brush replacement	1 years	1	\$650	\$ 650
Pumps repair (total)	5 years	1	\$1,410	\$ 282
Blowers repair (total)	10 years	1	\$3,230	\$ 323
Total Annual Cost (\$)				\$ 2,955

Major Overhaul Cost	Frequency (years)	Qty in system	Cost (\$)	Annual Cost (\$)
Fine Screen replacement	20 years	2	\$47,500	\$ 2,375
Diffuser membrane replacement (total)	7 years	1	\$5,000	\$ 714
EQ Blower replacement	20 years	2	\$6,000	\$ 300
Process Blower replacement	20 years	2	\$9,500	\$ 475
Membrane Blower replacement	20 years	2	\$6,000	\$ 300
Sludge Holding Tank Blower replacement	20 years	1	\$4,750	\$ 238
EQ pump replacement	20 years	2	\$2,500	\$ 125
Feed pump replacement	20 years	2	\$3,000	\$ 150
Membrane feed pump replacement	20 years	2	\$2,500	\$ 125
Permeate pump replacement	20 years	2	\$3,000	\$ 150
Sludge decant pump replacement	20 years	1	\$1,250	\$ 63
Membrane Modules	16 years	45	\$33,750	\$ 2,109
Total Annual Cost (\$)				\$ 7,124

Project No.: 1502057 - Phase 2 train

Project Name: Waldemar, ON, Wastewater Treatment Plant



Chemical Consumption Estimation

Membrane Tanks in Service: 1

Chlorine CIP Cleaning Frequency: 4 per year

Chlorine Recovery Cleaning Frequency: 1 per year

Citric Acid Recovery Cleaning Frequency: 1 per year

Purpose	Chemical	Bulk Chemical Concentration	Required Solution Concentration	Required Bulk Chemical per Procedure	Number of Procedures per Cell per Year	Number of Procedures per Year	Required Bulk Chemical per Year
1. Membrane Cleaning Chemicals							
Chlorine Clean-In-Place	Sodium Hypochlorite	12.0% w/w Liquid	500 ppm	0.6 L 0.7 kg	4	4	2.3 L 2.7 kg
Chlorine Recovery Clean	Sodium Hypochlorite	12.0% w/w Liquid	500 ppm	41.9 L 49.9 kg	1	1	41.9 L 49.9 kg
Citric Acid Recovery Clean	Citric Acid	30.0% w/w Liquid	0.5% w/w Liquid	100.6 L 112.7 kg	1	1	100.6 L 112.7 kg
2. Process Chemicals							
Alum dosing	Alum	N/A	N/A	30.5 L/d 40.73 kg/d	Continuous	Continuous	11,127.6 L 14,866.52 kg

Project No.: 1502057 - Phase 2 train

Project Name: Waldemar, ON, Wastewater Treatment Plant



Estimated Power Consumption

Equipment	Qty. Duty	Qty. Standby	Nameplate hp	Consumed hp at duty point	Total Installed hp	Total Consumed hp at duty point	Motor Efficiency	Total Operating hp	Total Operating kW	Daily Run Time (h/d)	Daily Operating (kWh/d)
Equalization Tank											
EQ Pumps (common)	1	1	0.5	0.45	1.00	0.45	85.00%	0.53	0.39	4	1.6
Headworks											
Fine Screens (common)	1	1	0.5	0.5	1.00	0.5	75.00%	0.67	0.50	4	2.0
Feed Pumps	1	0	0.75	0.72	0.75	0.72	75.00%	0.96	0.72	16	11.5
Anoxic Tank											
Immersion Heater	1	0	4	4	4.00	4	100.00%	4.00	2.98	8	23.9
Aeration Tank											
Immersion Heater	2	0	6.7	6.7	13.40	13.4	100.00%	13.40	10.00	8	80.0
Air Blowers	1	0	8.5	6.7	8.50	6.7	80.00%	8.38	6.25	24	149.9
Membrane Feed Pumps	1	0	2	1.6	2.00	1.6	85.00%	1.88	1.40	24	33.7
MBR Tank											
Air Scour Blowers	1	0	3.4	2.2	3.40	2.2	80.00%	2.75	2.05	22	45.1
Permeate Pumps	1	0	0.5	0.4	0.50	0.4	75.00%	0.53	0.40	20	8.0
Sludge Holding Tank											
Decant Pump (common)	1	0	1	0.8	1.00	0.8	75.00%	1.07	0.80	4	3.2
Sum					35.55	30.77			25.49		358.79

Project No.: 1502057 - Phase 2 train
 Project Name: Waldemar, ON, Wastewater Treatment Plant



Estimated Capital Equipment Replacement/Repair Cost

Maintenance Costs	Frequency (years)	Qty in system	Cost (\$)	Annual Cost (\$)
DO sensor	1 years	1	\$871	\$ 871
pH sensor	1 years	1	\$871	\$ 871
Pumps repair (total)	5 years	1	\$890	\$ 178
Blowers repair (total)	10 years	1	\$1,620	\$ 162
Total Annual Cost (\$)				\$ 2,082

Major Overhaul Cost	Frequency (years)	Qty in system	Cost (\$)	Annual Cost (\$)
Diffuser membrane replacement	7 years	1	\$2,500	\$ 357
Process Blower replacement	20 years	1	\$4,750	\$ 238
Membrane Blower replacement	20 years	1	\$3,000	\$ 150
Feed pump replacement	20 years	1	\$1,500	\$ 75
Membrane feed pump replacement	20 years	1	\$1,250	\$ 63
Permeate pump replacement	20 years	1	\$1,500	\$ 75
Membrane Modules	16 years	45	\$33,750	\$ 2,109
Total Annual Cost (\$)				\$ 3,067